



Purevista Ltd
Pendewey Farm
Stony Lane
Bodmin
Cornwall
PL31 2QX

Report No 45447/S/1

Posi-glaze Frameless Balustrade Product

Mount type test

(Line Load Test)

Testing Carried Out by Sandberg LLp

SANDBERG

Sandberg LLp
5 Carpenters Place
Clapham High Street
London
SW4 7TD

T:- 020 7565 7000

F:- 020 7565 7101

E-mail:- mail@sandberg.co.uk

Web:- www.sandberg.co.uk

Posi-glaze Frameless Balustrade Product

Mount type test

(Line Load Test)

Contents	
Introduction/Materials	3
Glass Types/Test Method	4
Remarks	5
Posi-Glaze Dimensions and Hole centres	7/8
Posi-Glaze Cross sectional Renders	9
Posi-Glaze Test Results	11-14

Posi-glaze Frameless Balustrade Product

Mount type test

(Line Load Test)

Test Instruction

The Instruction issued to Sandberg by Purevista was to witness line load type testing of the Posi-Glaze balustrade mounting section for compliance with the performance requirements, under a uniformly distributed horizontal load (UDL), that are defined in clauses 6.4.1 and 8.5.1 of BS 6180:2011.

Introduction

Purevista has designed and had manufactured an extruded aluminium section called Posi-Glaze that is intended for the use as a bottom mount for frameless glass balustrade that have no need for intermediate posts.

At the request of Purevista, a representative from Sandberg witnessed the testing of the Posi-glaze balustrade system. The test programme included appraisal of several types of glazing with the Posi-Glaze section fitted to both steel and concrete substrates, mounted on either a vertical or horizontal surface.

The testing was undertaken at Purevista's premises on 12th January 2012.

Materials

The Posi-glaze section is formed in extruded aluminium (6063 T6) with an overall height of 111mm and a width of 72mm excluding trims (photo XX). Cross-sectional details of the system are shown on a Purevista drawing (below). In Appendix A which also includes an illustration depicting the glass mounting arrangement.

The Following configurations for mounting the Posi-glaze extrusion were included in the test programme:-

1. Concrete substrate, attachment to a top surface (base fixed)
2. Concrete substrate, attachment to a vertical face (face fixed)
3. Steel substrate, attachment to a top face (base fixed)
4. Steel substrate, attachment to a vertical face (face fixed)

For each mounting arrangement four different glass types were tested, overall performance of the system being a function of the rigidity of the mounting, and the stiffness of both the Posi-glaze section and the glass in situ.

In all cases the Posi-glaze was mounted to the substrate using 12mm bolts set in the pre-drilled counter-bored holes spaced at 200mm centres. The 1.0m long test section of Posi-Glaze was provided with five anchor bolts. On the concrete substrate the bolts were Spit Guardia 12 x 105/20 expanding anchors, while on the steel substrate they were grade 10.9 hexagon headed M12 bolts.

The Standard arrangement of anchor holes is shown on further Purevista drawings reproduced in Appendix A.

Glass Types

Four glass types were included in the test programme, all dimensioned such that the balustrade head, when fitted with a handrail section, was approximately 1100mm above the horizontal surface of the substrate. All of the glass panels tested were 1000mm long. The four glass types were:-

1. 15mm toughened, heat soaked float glass, polished edges
2. 19mm toughened, heat soaked float glass, polished edges
3. 21.5mm (10mm - 1.5mm interlayer – 10mm) EVA laminated, toughened, heat soaked glass, polished edges
4. 21.5mm (10mm - 1.5mm interlayer – 10mm) Dupont SentryGlas, laminated, toughened, heat soaked glass with a stiff polymer interlayer, polished edges

Test Method

The tests undertaken were exclusively for a uniformly distributed horizontal load applied at a level as close as possible to a design level of 1100mm above the horizontal surface below or adjacent to the barrier.

The test procedure entailed mounting a 1.0m length of Posi-Glaze section onto a substrate of either concrete or steel; the assembly was then positioned in a test frame. Glass was installed into the frame and adjusted until accurately vertical. The glass was 1.0 metres long and of a height sufficient, when fitted with a handrail, to achieve a top level of approximately 1100mm above the horizontal surface at or adjacent to the base. A measured horizontal load was applied, through a spreader, centrally onto the handrail section that had been fitted onto the top of the glass.

Load was applied using a small hydraulic piston and was measured using a calibrated load cell (S-Beam No. 587783/085097 calibrated by Westwood Instrument Services Limited) fitted with a digital readout.

Deflection of the glass immediately below the handrail section was measured using a 50mm travel dial gauge reading in increments of 0.01mm (Bluerange Tools Serial No. 3515)

In each case load was applied in increment appropriate to various requirements arising in British and German National Standards. Where of additional interest, the load necessary to cause a 25mm deflection was also measured.

In free-standing glass protective barriers subject to their full design load, applied at the design height for the panel, BS 6180:2011 (clauses 6.4.1 and 8.5.1) limits deflection of glass at any point on the panel to a maximum of 25mm

Results

The test results are detailed in Appendix B; these are divided into the four categories of base configuration as described in Section 2. Within each configuration the individual glass types yielded differing performance results.

Remarks

For each of the base configurations examined and tested with a horizontal uniformly distributed load of up to 1.5kN/m, applied at a design level of 1100mm, there is a glazing type that will fulfil the BS performance requirement of a maximum deflection not exceeding 25mm.



Appendix A

Purevista Details Posi-Glaze

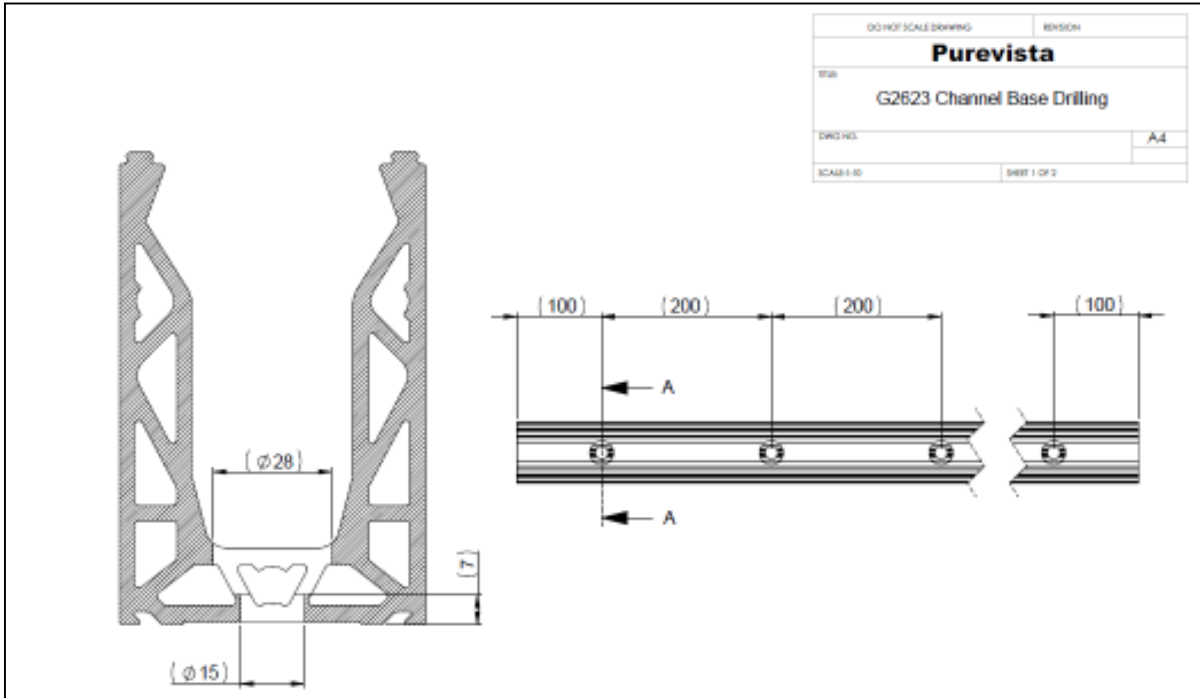

Figure B1 Bottom Mounting holes in Posi-Glaze

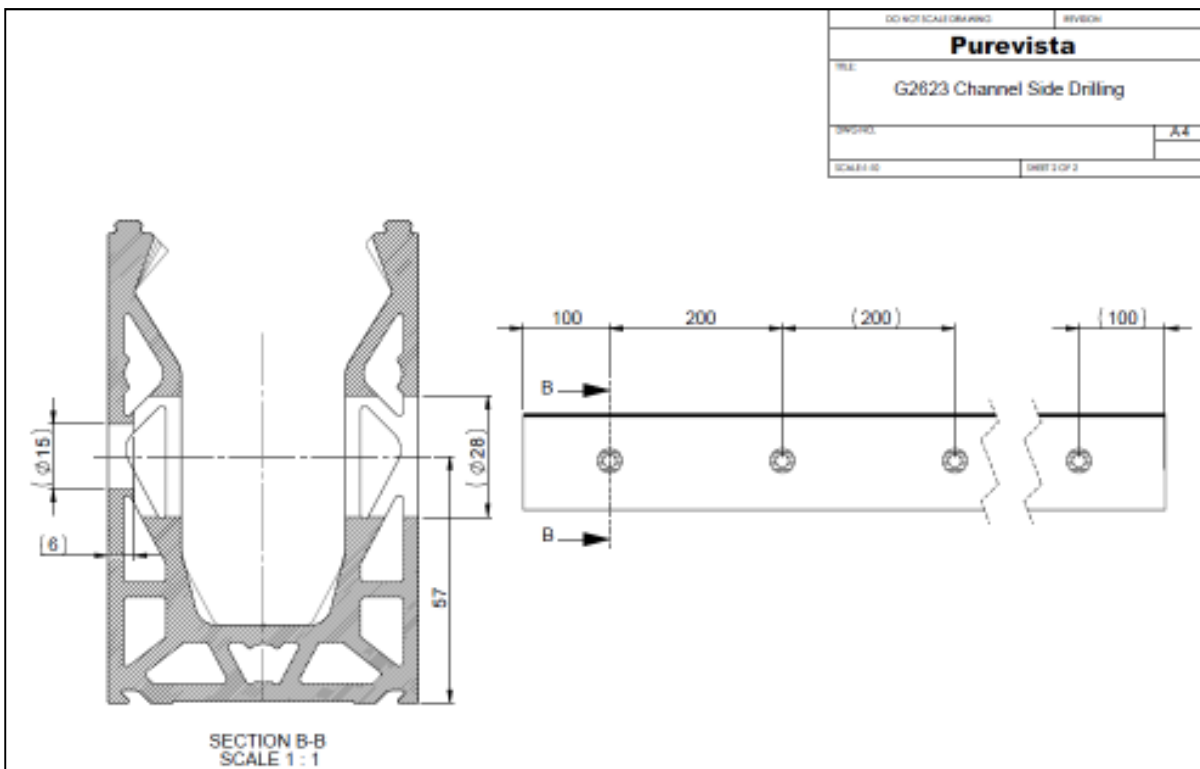

Figure B2 Side Mounting holes in Posi-Glaze

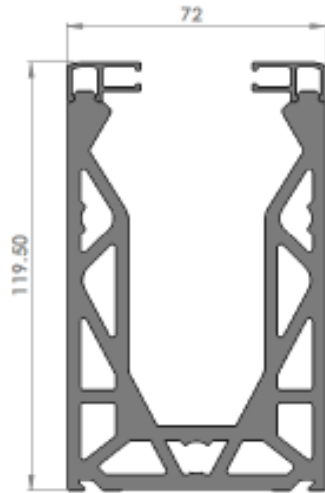

Figure B3 Posi-Glaze Dimensions With Top Seal

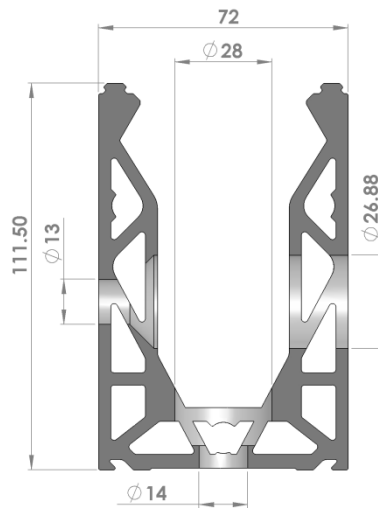

Figure B4 Posi-glaze dimension Channel only

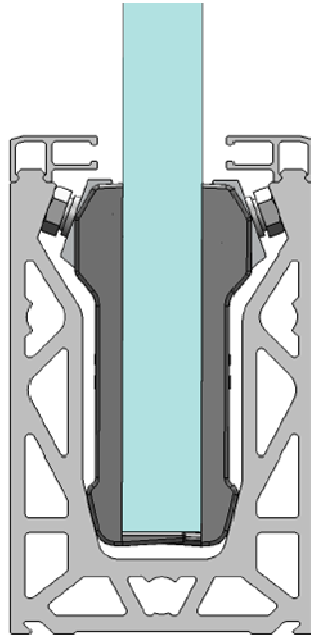

Figure B5 Cross Section through Posi-Glaze Mount

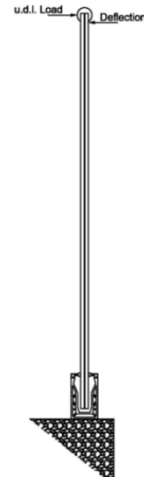
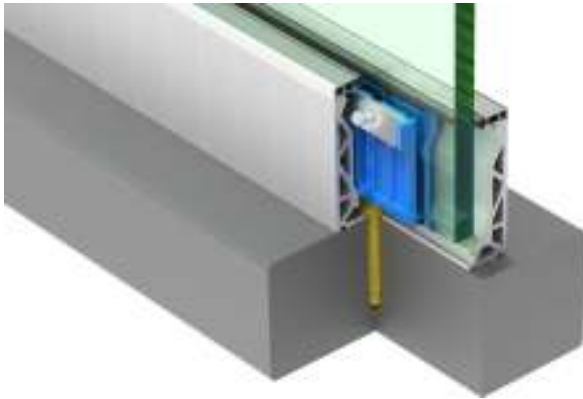

Figure B6 Illustration of glass mounting arrangement

Appendix B

Posi-Glaze Test Results

Base Fixed onto Concrete



Fixing and test Method

Glass Type	Horizontal U.D.L. Kn/M	Height mm	Deflection mm
15mm Toughened, Heat Soaked	0.74	1120	18.20
15mm Toughened, Heat Soaked	0.98	1120	25.03
19mm Toughened, Heat Soaked	0.74	1095	9.93
19mm Toughened, Heat Soaked	1.00	1095	14.30
19mm Toughened, Heat Soaked	1.50	1095	21.80
19mm Toughened, Heat Soaked	1.63	1095	25.00
21.5mm EVA Laminated Toughened, Heat Soaked	0.74	1093	15.45
21.5mm EVA Laminated Toughened, Heat Soaked	1.07	1093	25.00
21.5mm Rigid Laminated Toughened, Heat Soaked	0.74	1116	9.60
21.5mm Rigid Laminated Toughened, Heat Soaked	1.00	1116	13.68
21.5mm Rigid Laminated Toughened, Heat Soaked	1.50	1116	22.70
21.5mm Rigid Laminated Toughened, Heat Soaked	1.56	1116	25.00

Side Fixed Onto Concrete

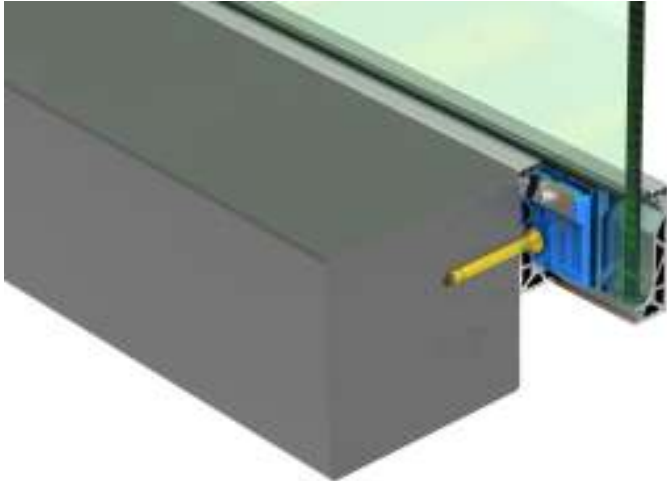

Test Method

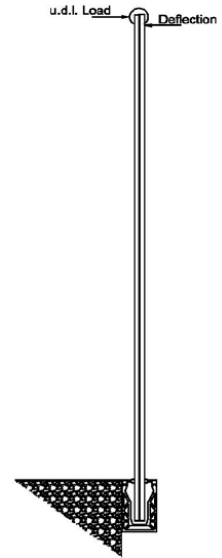

Fixing and

Glass Type	Horizontal U.D.L. kN/m	Height mm	Deflection mm
15mm Toughened, Heat Soaked	0.36	1100	11.65
15mm Toughened, Heat Soaked	0.71	1100	25.00
19mm Toughened, Heat Soaked	0.74	1093	15.38
19mm toughened, Heat Soaked	1.05	1093	25.10
21.5mm EVA Laminated Toughened Heat Soaked	0.36	1085	8.37
21.5mm EVA Laminated Toughened, Heat Soaked	0.74	1085	18.65
21.5mm EVA Laminated Toughened, Heat Soaked	0.95	1085	25.00
21.5mm Rigid Laminated Toughened, Heat Soaked	0.74	1100	13.20
21.5mm Rigid Laminated Toughened, Heat Soaked	1.00	1100	19.43
21.5mm Rigid Laminated Toughened, Heat Soaked	1.15	1100	25.00

Base Fixed Onto Steel

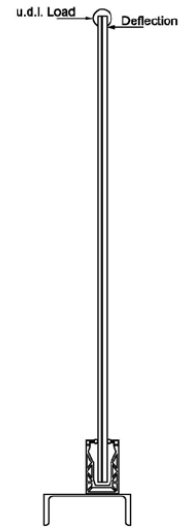
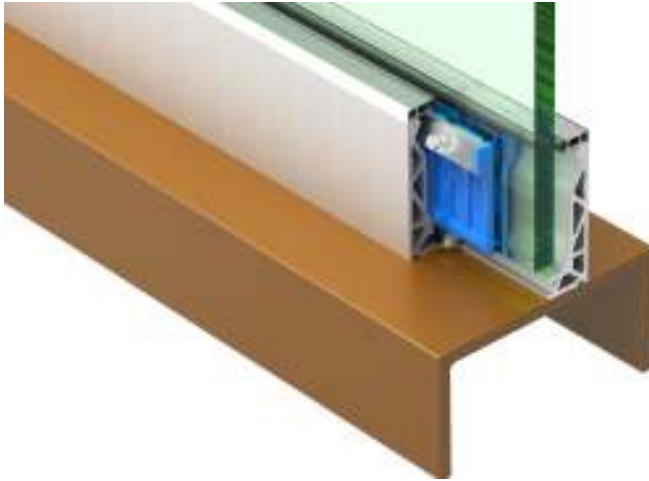

Fixing and Test Method

Glass Type	Horizontal U.D.L. kN/m	Height mm	Deflection mm
15mm Toughened Heat Soaked	0.36	1118	9.10
15mm Toughened Heat soaked	0.74	1118	19.71
15mm Toughened Heat Soaked	0.85	1118	25.00
19mm Toughened Heat Soaked	0.74	1097	10.21
19mm Toughened Heat Soaked	1.50	1097	23.76
21.5mm EVA Laminated Toughened Heat Soaked	0.36	1098	7.12
21.5mm EVA Laminated Toughened Heat Soaked	0.74	1098	15.82
21.5mm EVA Laminated Toughened Heat Soaked	1.00	1098	22.64
21.5mm EVA Laminated Toughened Heat Soaked	1.06	1098	25.00
21.5mm Rigid Laminated Toughened Heat Soaked	0.36	1118	4.71
21.5mm Rigid Laminated Toughened Heat Soaked	0.74	1118	10.50
21.5mm Rigid Laminated Toughened Heat Soaked	1.00	1118	14.77
21.5mm Rigid Laminated Toughened Heat Soaked	1.50	1118	22.46
21.5mm Rigid Laminated Toughened Heat Soaked	1.60	1118	25.18

Side Fixed Onto Steel

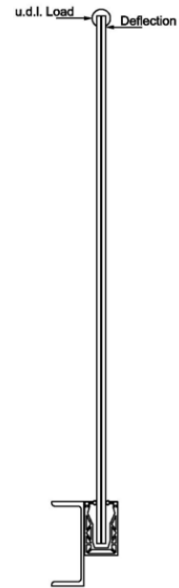

Fixing and Test Method

Glass Type	Horizontal U.D.L. kN/M	Height mm	Deflection mm
15mm Toughened Heat Soaked	0.36	1113	10.35
15mm Toughened Heat Soaked	0.74	1113	24.50
19mm Toughened Heat Soaked	0.74	1101	17.60
19mm Toughened Heat Soaked	0.91	1101	25.00
21.5mm EVA Laminated Toughened Heat Soaked	0.36	1090	8.09
21.5mm EVA Laminated Toughened Heat Soaked	0.74	1090	18.85
21.5mm EVA Laminated Toughened Heat Soaked	0.89	1090	25.00
21.5mm Rigid Laminated Toughened Heat Soaked	0.36	1112	6.31
21.5mm Rigid Laminated Toughened Heat Soaked	0.74	1112	13.13
21.5mm Rigid Laminated Toughened Heat Soaked	1.00	1112	20.50
21.5mm Rigid Laminated Toughened Heat Soaked	1.08	1112	25.00

Red writing indicates maximum loading up to the 25mm maximum deflection as per BS 6180:2011

This report is personal to the client, non-assignable and written with no admission of liability to any third party.

This report shall not be re-produced, without written approval of Purevista Ltd

The results and conclusions relate only to the samples tested